

Atlas
zum
modernen Transportwesen
im Dienste
der Land- und Forstwirthschaft.

Für Agricultur- und Forst-Ingenieure, Eisenbahnbauer und Industrielle.

Von

Regierungsrath Dr. W. F. Exner,

o. ö. Professor der mechanischen Technologie und des forstlichen Ingenieurwesens an der k. k. Hochschule für Bodenkultur und a. ö. Professor an der Handelshochschule in Wien.

Enthaltend 15 Folio-Tafeln mit 131 Figuren.

Sächsische

5 | A

3601

Landesbibl.

 Der hierzu gehörige Text ist in einem besonderen Bande beigegeben.

E, W[ilhelm] F[rantz]

Faint, illegible text at the top left of the page.

Faint, illegible text in the upper middle section of the page.

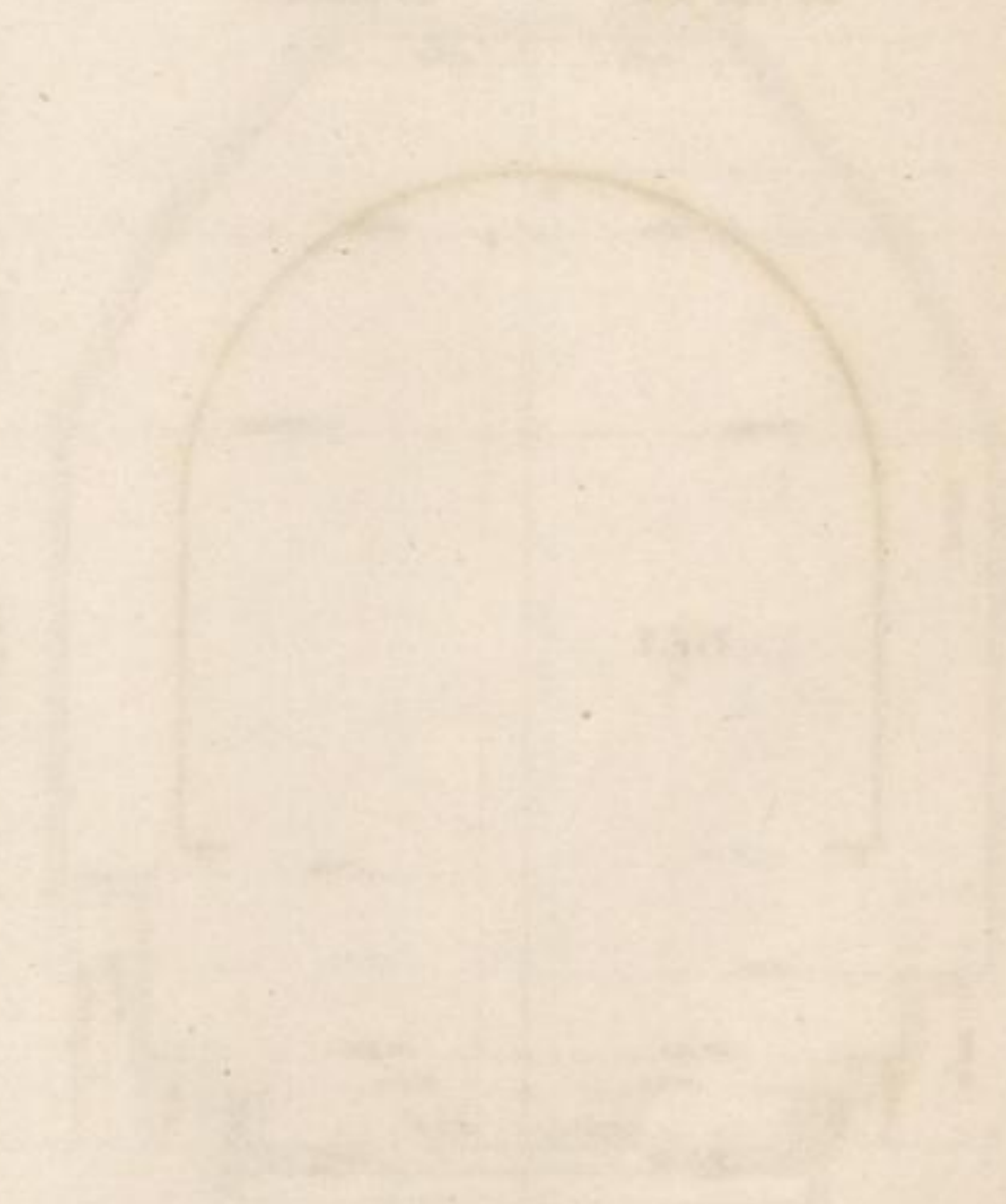

Faint, illegible text in the lower left section of the page.

Handwritten or stamped text in the bottom right corner, including the date "21 JAN 1881" and the word "Dresden".

Normal-Profil
des lichten Raumes u. Maximal-Ladeprofil a b c.
bei normaler Spurweite

für
die freie Bahn, für die Bahnhöfe.

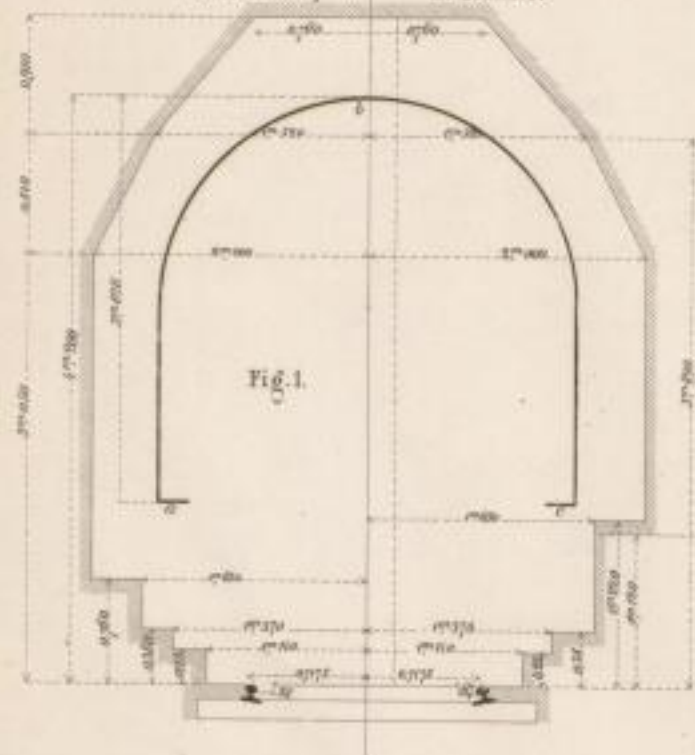

Normal-Profil
des lichten Raumes u. Maximal-Ladeprofil a b c.
für schmalspurige Bahnen von 1^m Spur.

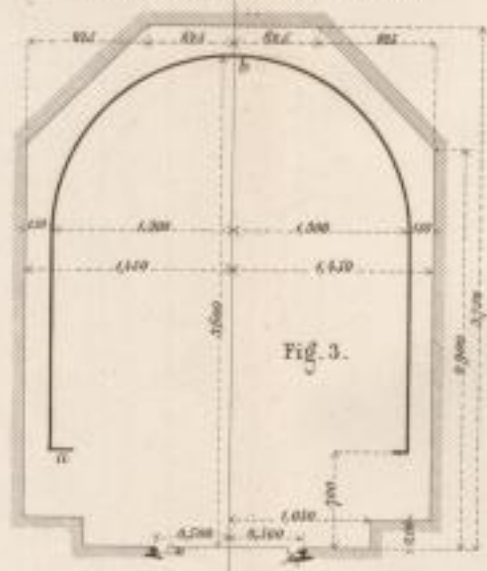

Normal-Profil
des lichten Raumes u. Maximal-Ladeprofil a b c.
für schmalspurige Bahnen von 0,75 Spur.

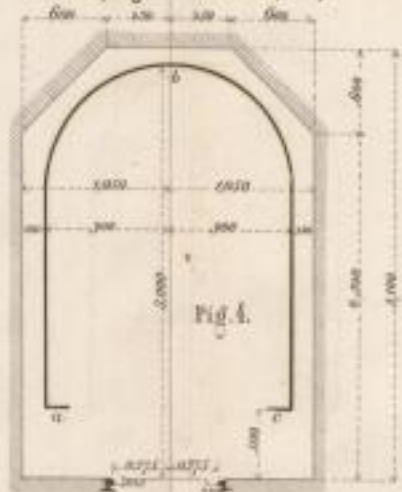

Maßstab 1:50

Normal-Profil
des lichten Raumes
bei normaler Spurweite

für
die freie Bahn, für die Bahnhöfe.

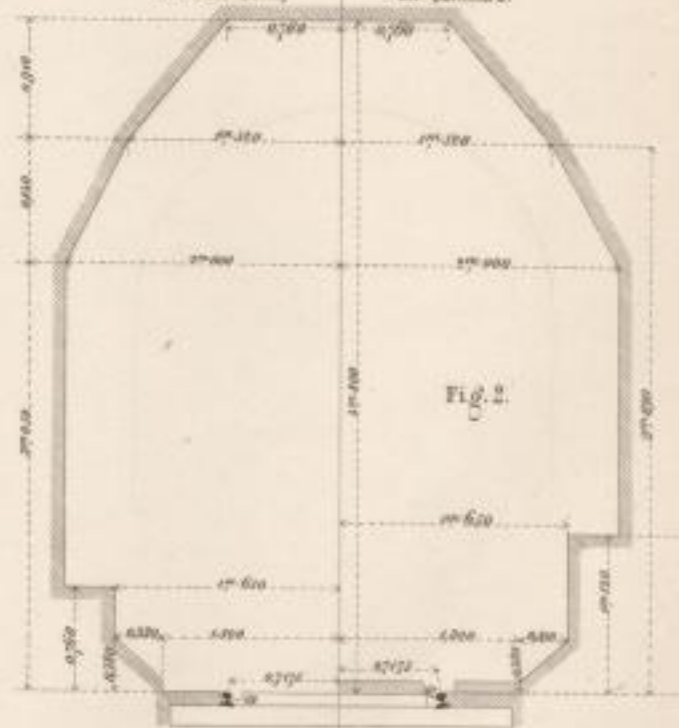

Maßstab 1:50 mit Gr.

Sächsische
Landesbibliothek
21. JAN 1987
Dresden

Handwritten text, possibly a title or heading, located in the upper left quadrant of the page.

Handwritten text, possibly a subtitle or a line of a list, located below the first block of text.

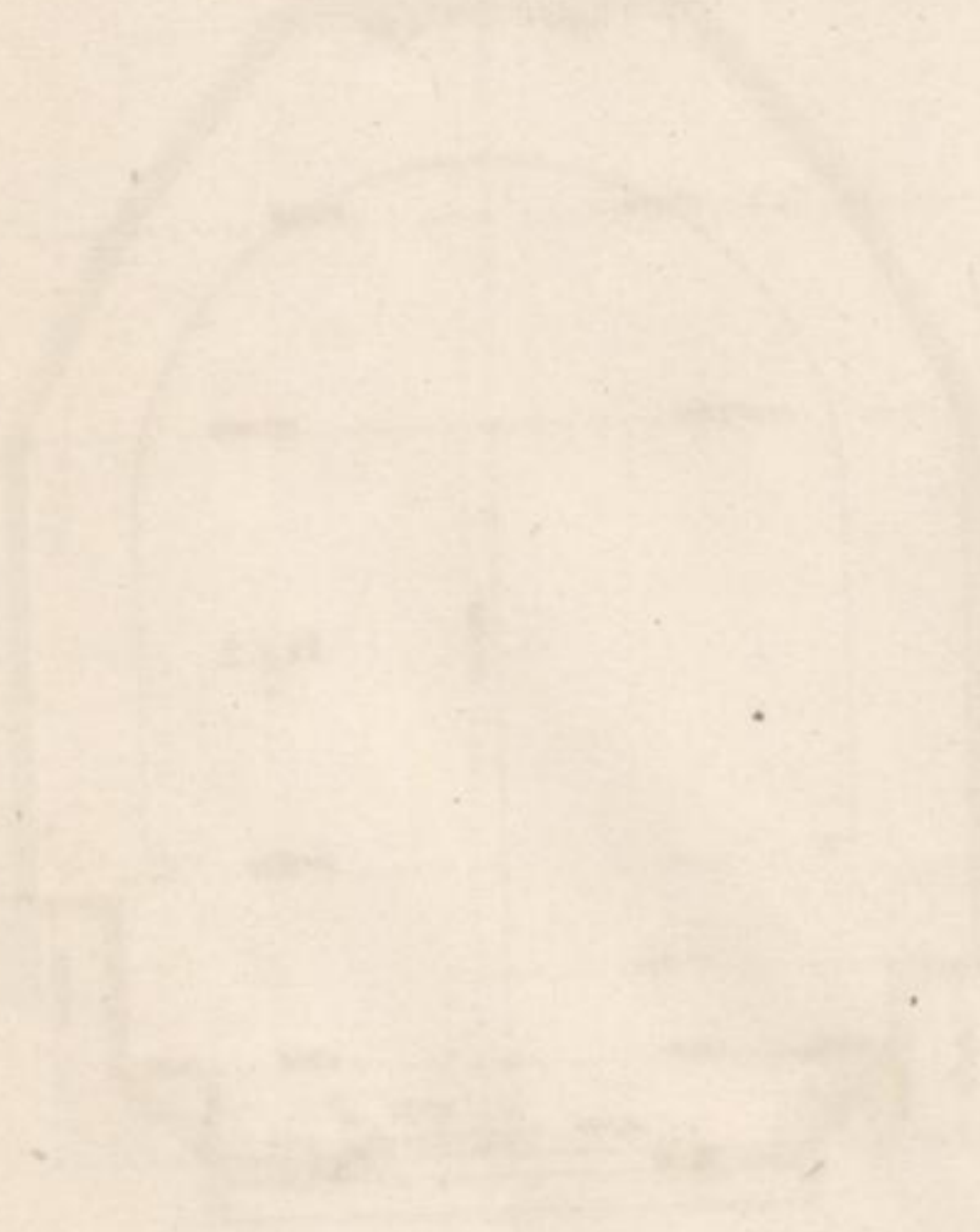

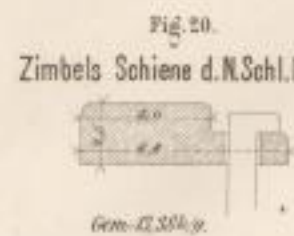
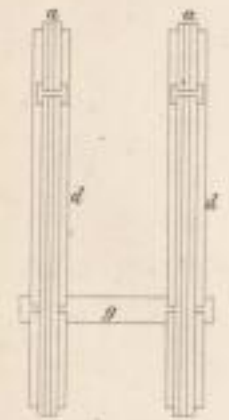
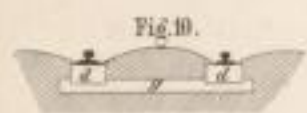

Eiser. Transportriemen.

[Faint, illegible text, likely bleed-through from the reverse side of the page]



Wiener Pferde B.



Magdeb.-Leipzig E.B.

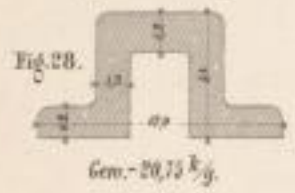

St. Louis, Strassenbahn.

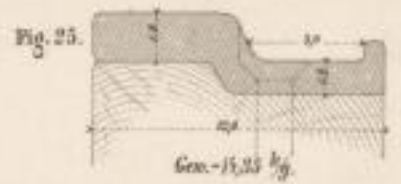

Badische Staats E.B.

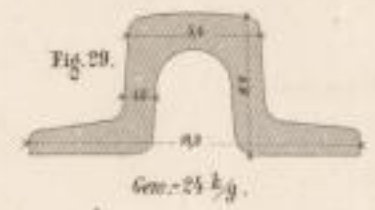

New York, III Avenue.

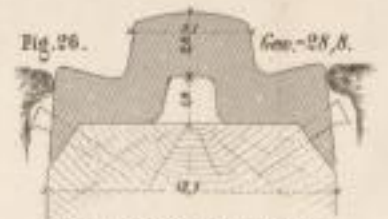

Seaton's Sattelschiene.

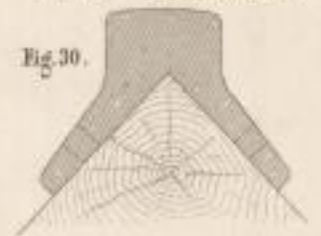

Profile von Stahlschienen.

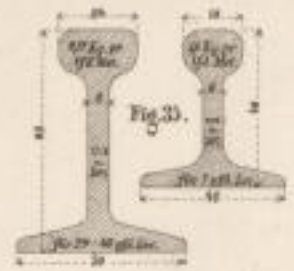

181

1. Seite

2. Seite

3. Seite

4. Seite

5. Seite

Fig. 39.



1/2 d.n.Gr.

Uetli-Bergbahn.

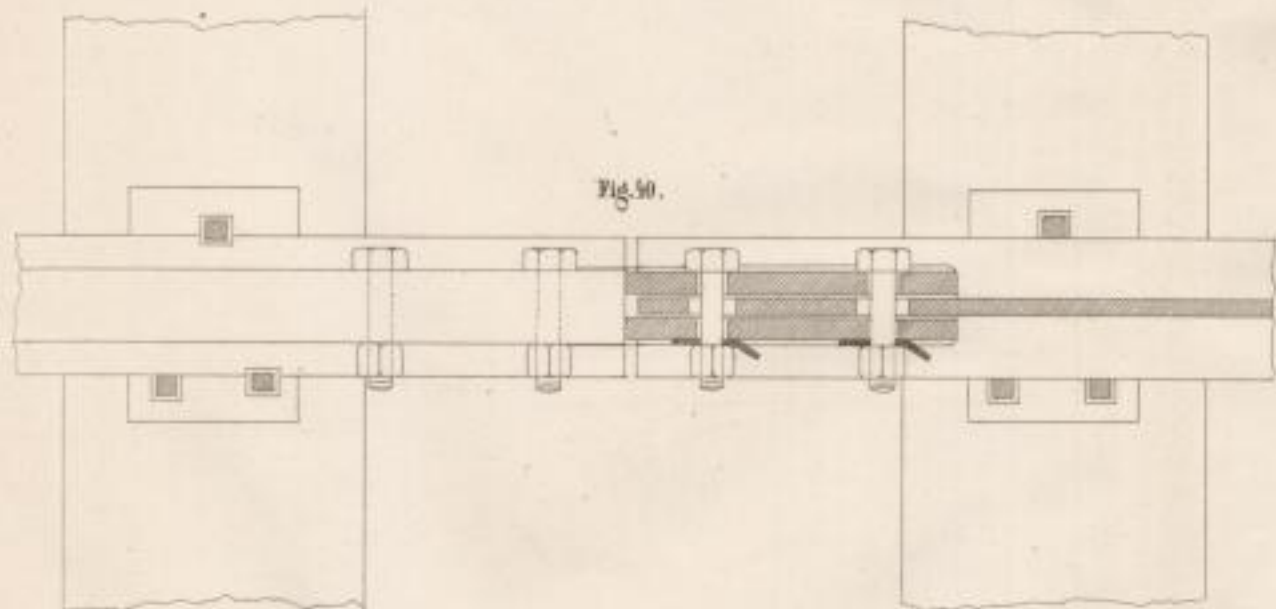

Fig. 50.

Fig. 41.

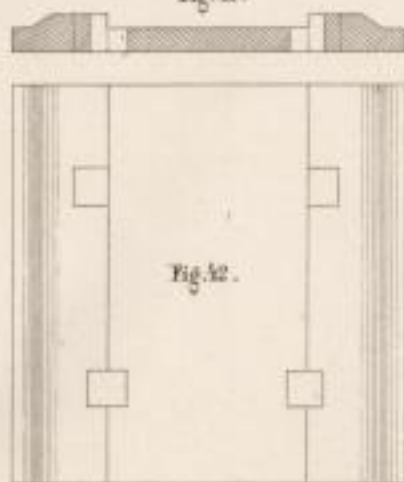

Fig. 42.

Fig. 43.



Fig. 44.

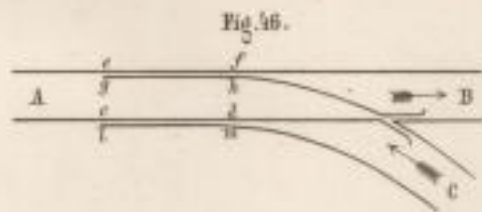
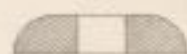

Fig. 46.

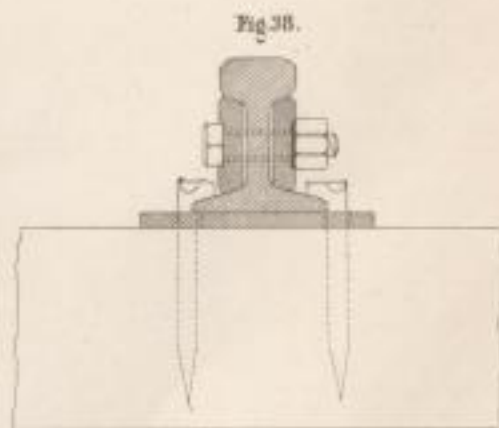

Fig. 48.

1/2 d.n.Gr.



Fig. 45.

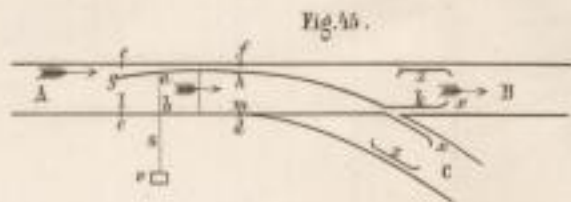

Fig. 47.

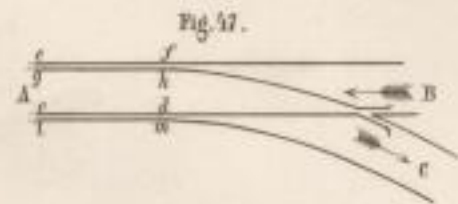

Fig. 49.

11. 187

11. 187

11. 187

11. 187

11. 187

11. 187

11. 187

11. 187



11. 187

11. 187





Fig. 50.



Fig. 51.

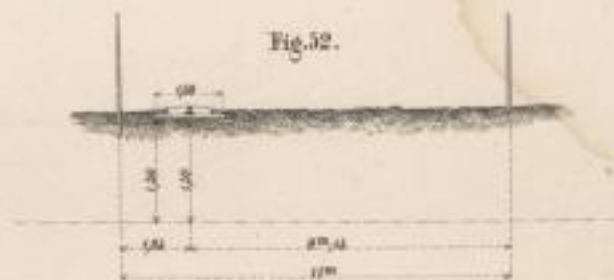

Fig. 52.

Holzbahn in Mureny-Jolsva.

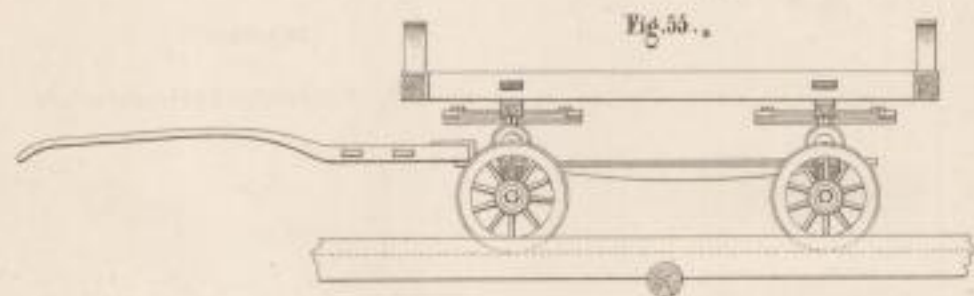

Fig. 55.

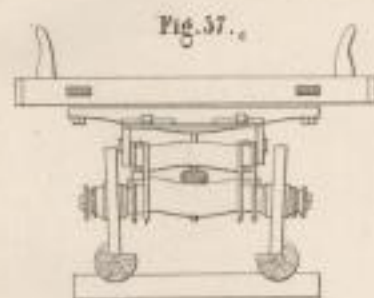

Fig. 57.

Längenprofil der Wolfsegg-Traunthaler Kohlenwerk-Bahn.



Fig. 56.

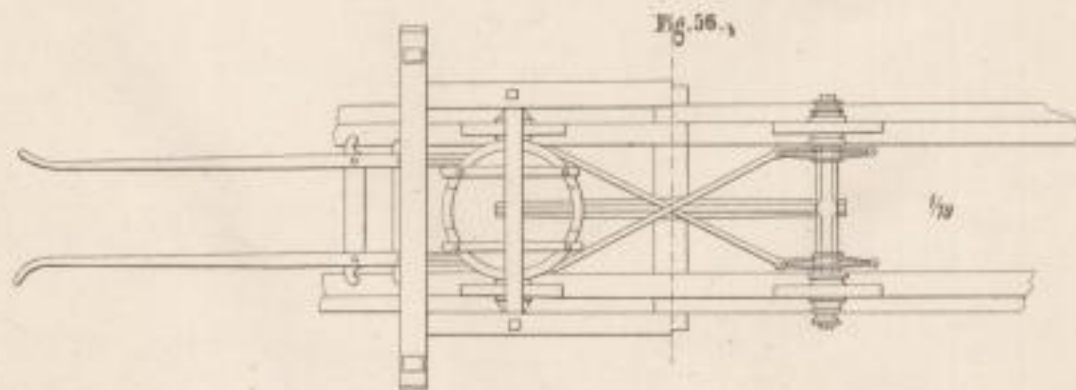

Fig. 56.

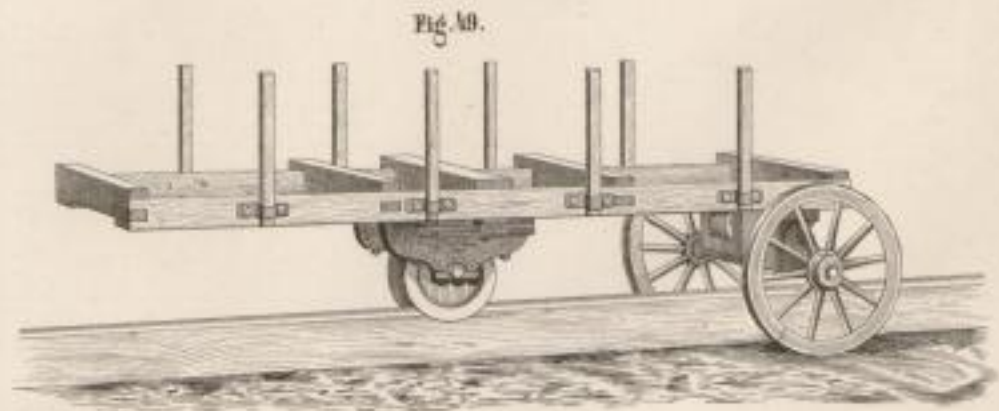

Fig. 58.

Exter, Transportwagen.

111

1811

1811

1811

1811

1811



1811

1811

1811

1811

1811

Holzbahn in Murany-Jolova.

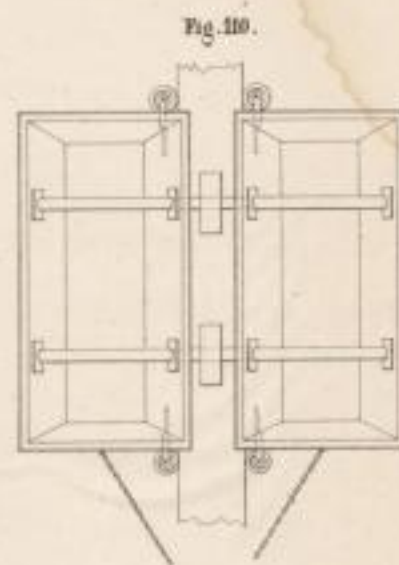
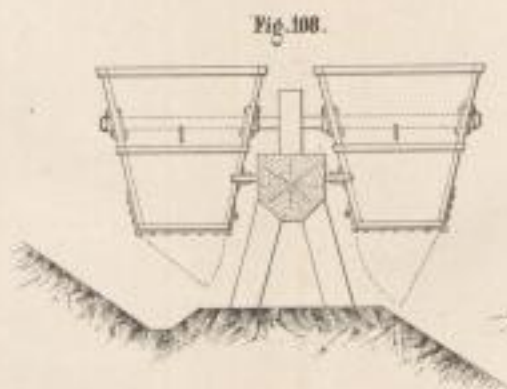
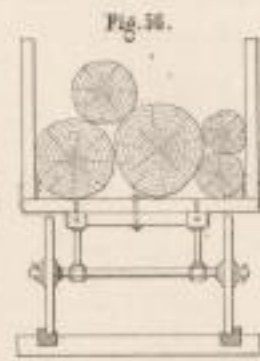
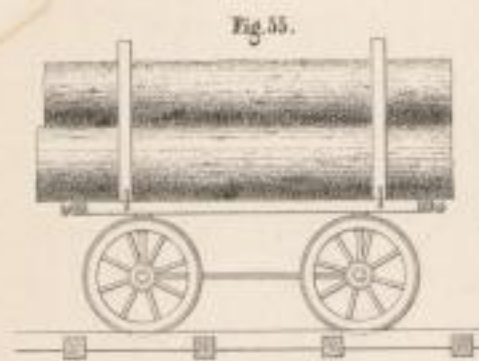

Axenstellung in der Curve.

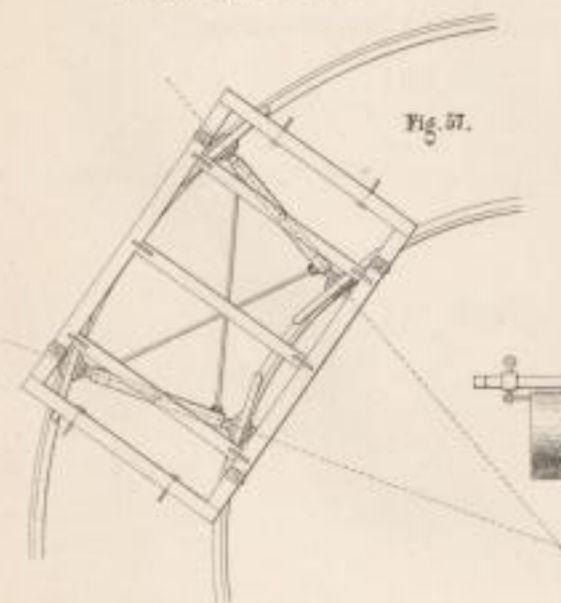

Zweirädriger Klotzwagen.

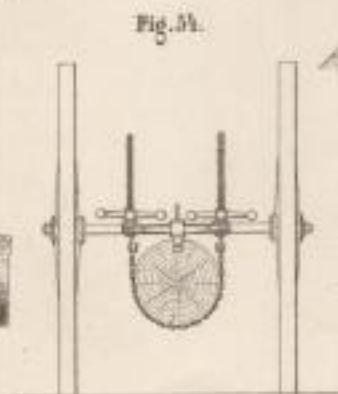
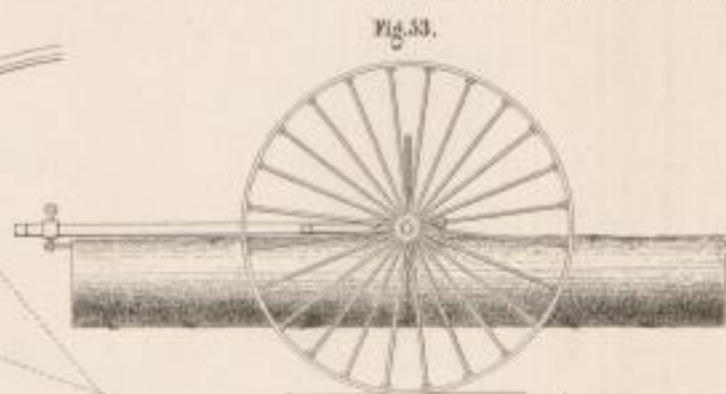

Oberbau für Forst- und Industriebahnen.

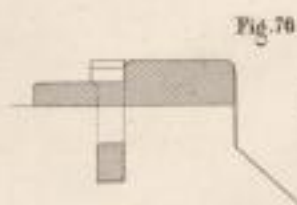

Original Zeichnung

1817

1817

Geometrie der Festungsbaukunst

Abhandlung von...

...

...



...

...

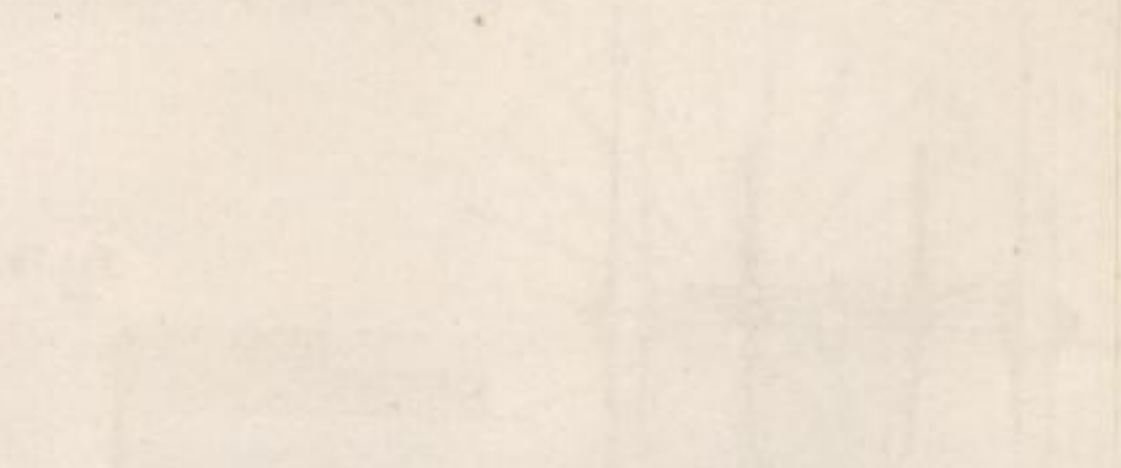

1844

1844

1844



1844

1844

1844

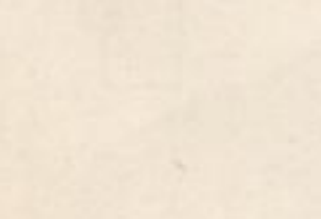

Eisenbahn in Jdria.

Fig. 58.

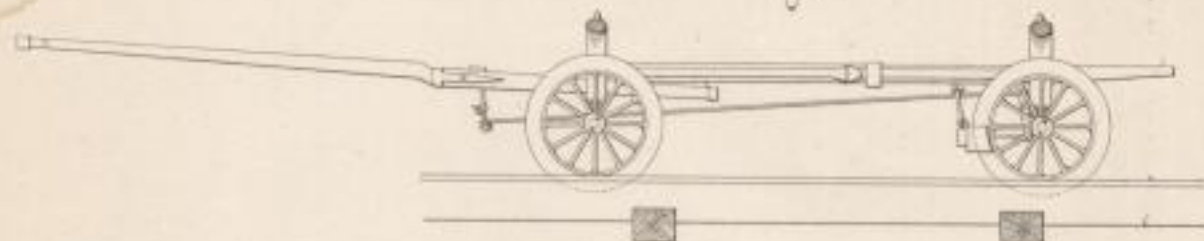

Fig. 59.

Fig. 60.

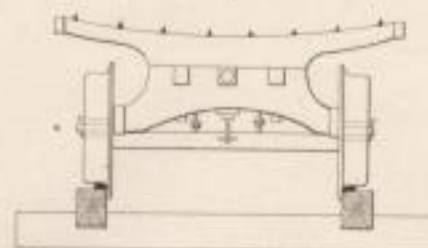

Fig. 123.



Brennholz-Aufzug.

Fig. 50.

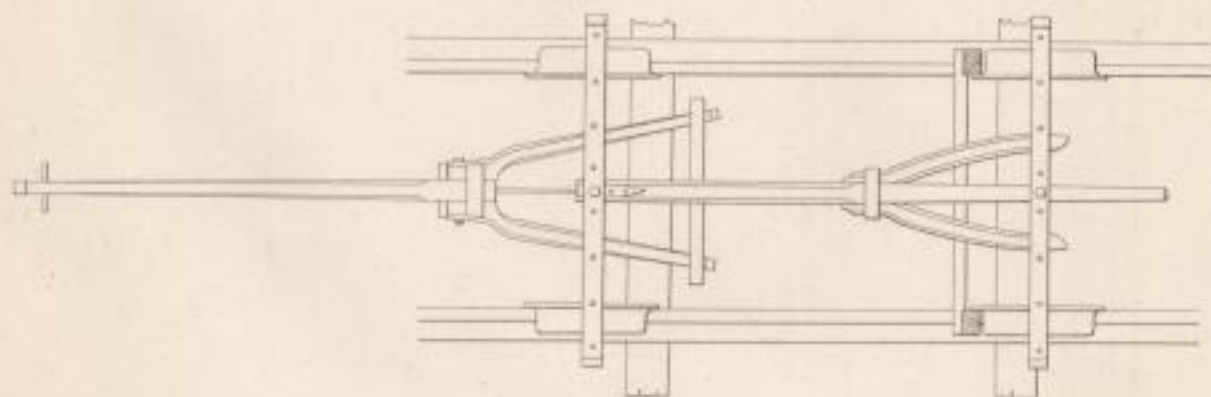

Fig. 122.

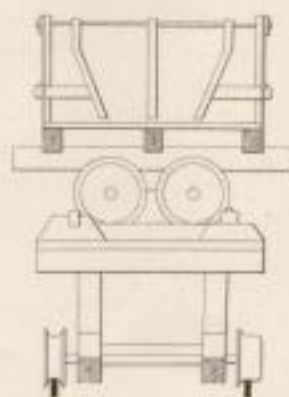
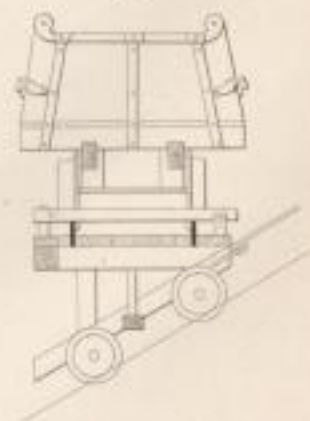

Fig. 121.



Digital Zeichnung

Tafel VII



Stahl-Bohrer





Handwritten text, likely bleed-through from the reverse side of the page.

Handwritten text, likely bleed-through from the reverse side of the page.

Handwritten text, likely bleed-through from the reverse side of the page.

Fig. 63. 67. 71.

Holzbahn auf der Herrschaft Račach in Krain.

System Lo-Presti.

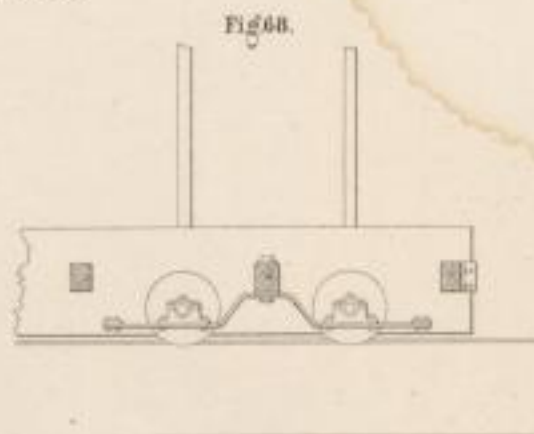
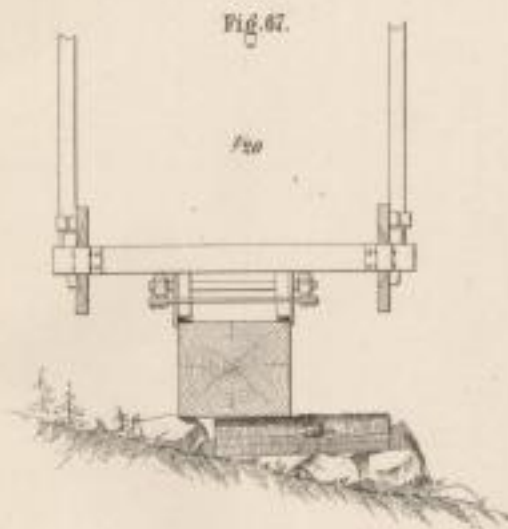
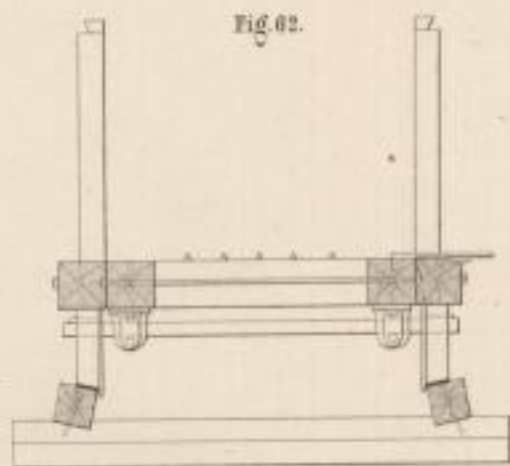
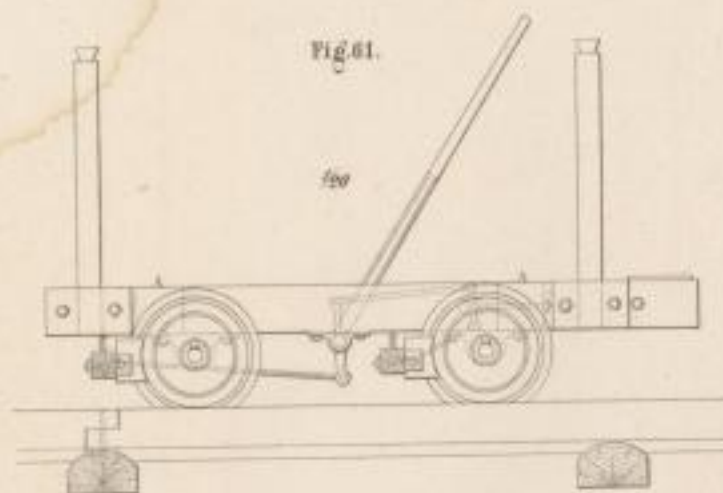

Original-Zeichnung

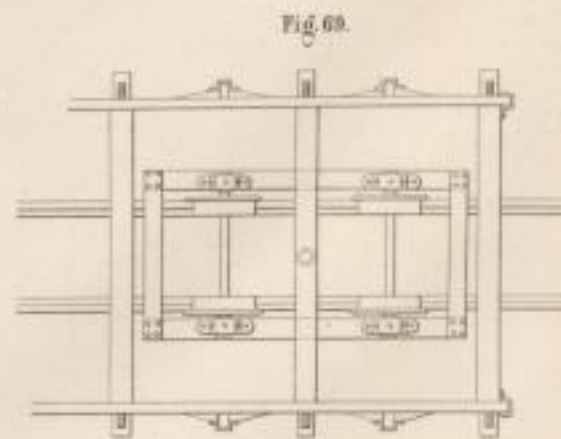
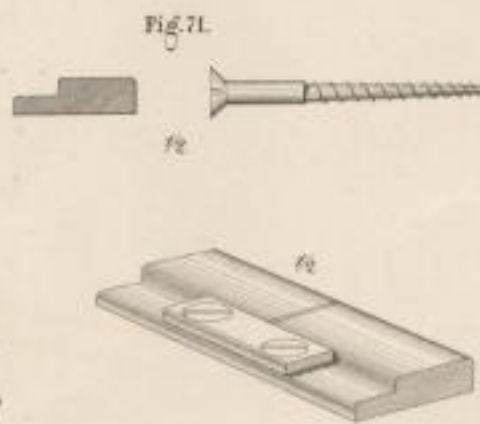
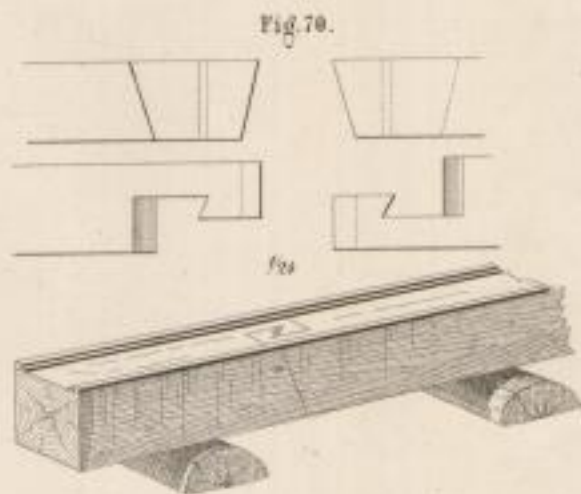
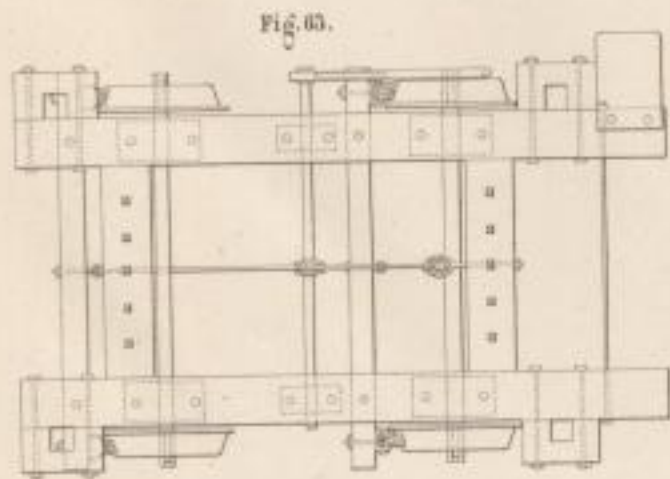

Einer Transportmaschine

REV. 1817

REV. 1817

REV. 1817

REV. 1817

REV. 1817

REV. 1817

REV. 1817

REV. 1817

Handwritten text, likely a title or header, which is extremely faint and difficult to decipher.

A large, faint table or grid structure, possibly a ledger or account book, with multiple columns and rows. The content is illegible due to fading.

Lowry mit Selbstbremse von Scheyer.

Waidhofener Langholzwagen.

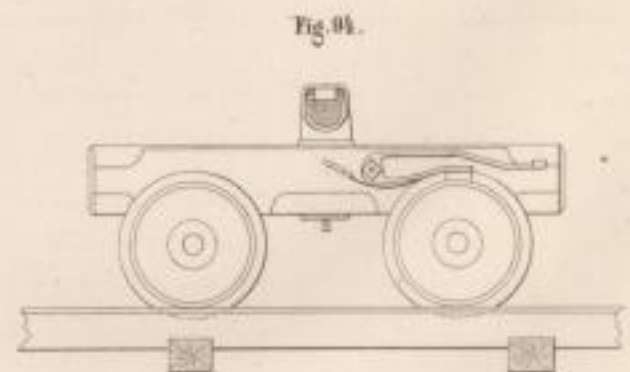
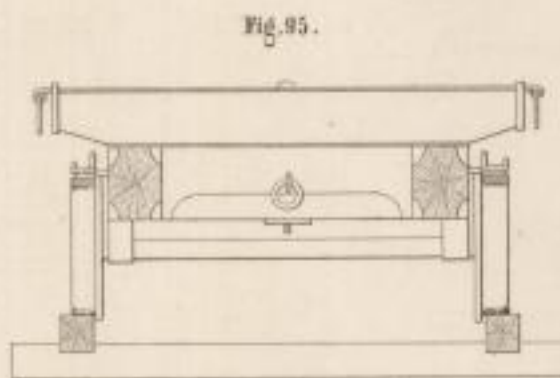
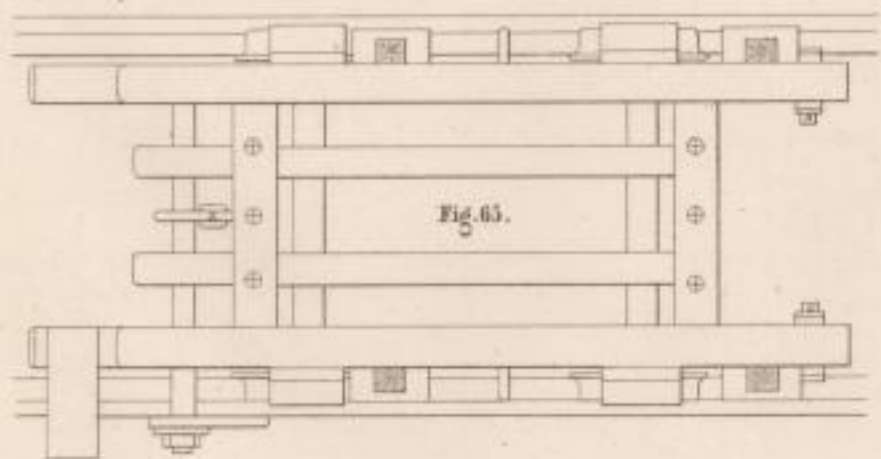
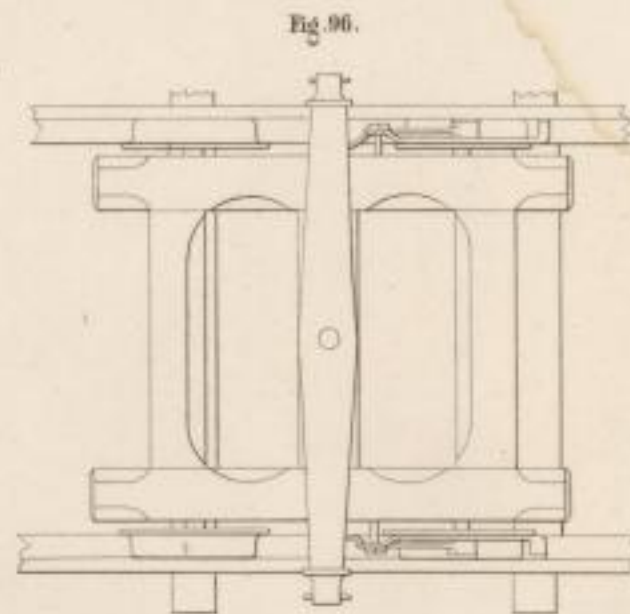
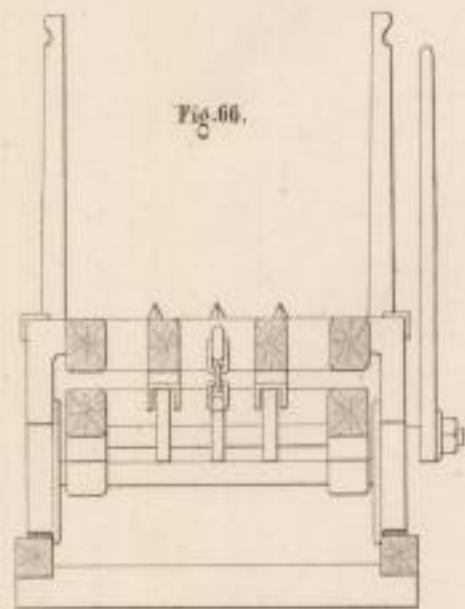
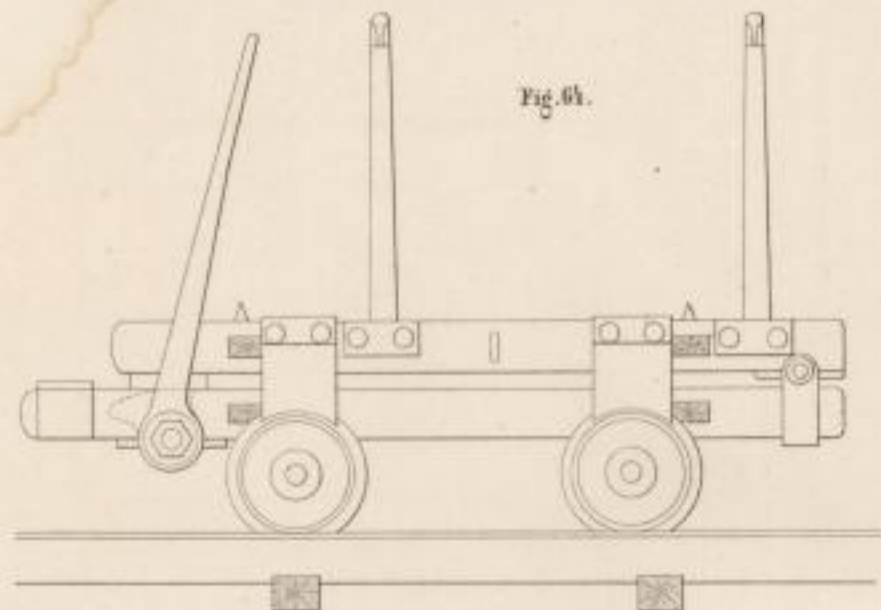

Digital Library

11. Tafel

Verbreitung der Leptodermiden



1874. 27. 27. 1874

[Faint, illegible handwriting, possibly bleed-through from the reverse side of the page]

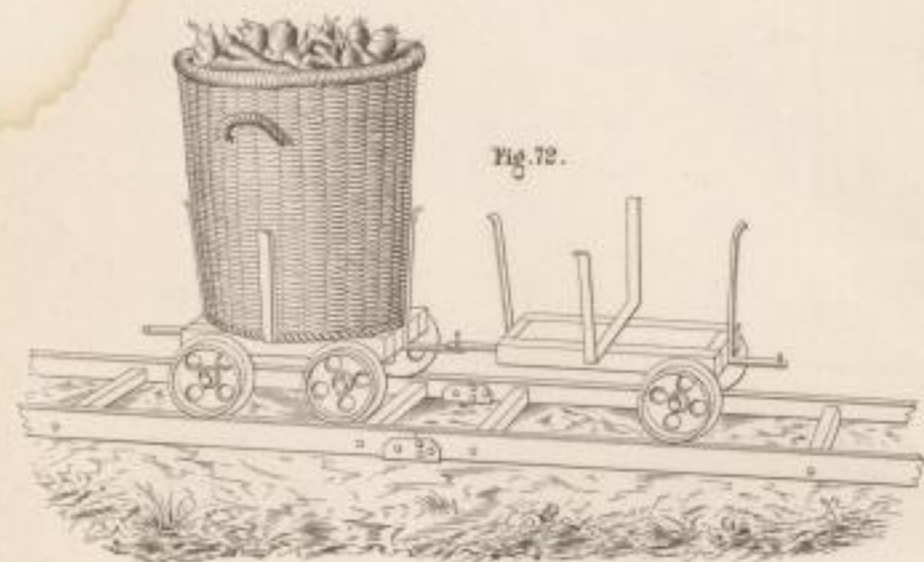

Fig. 72.

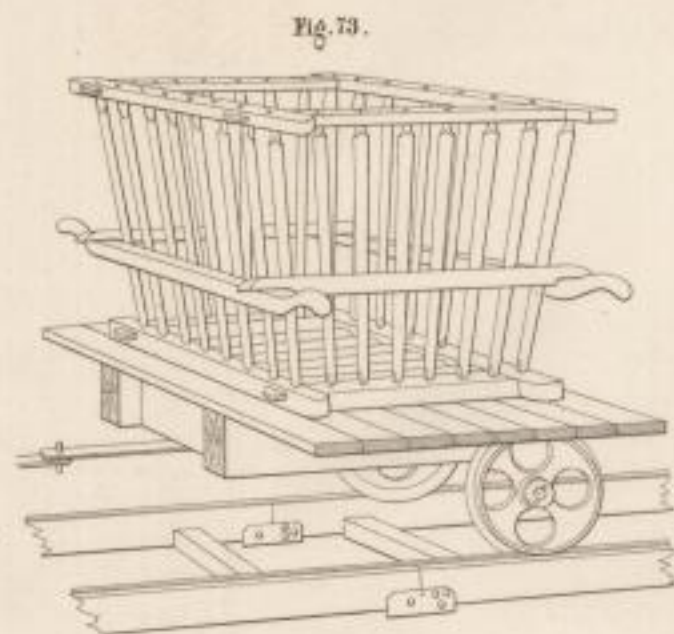

Fig. 73.

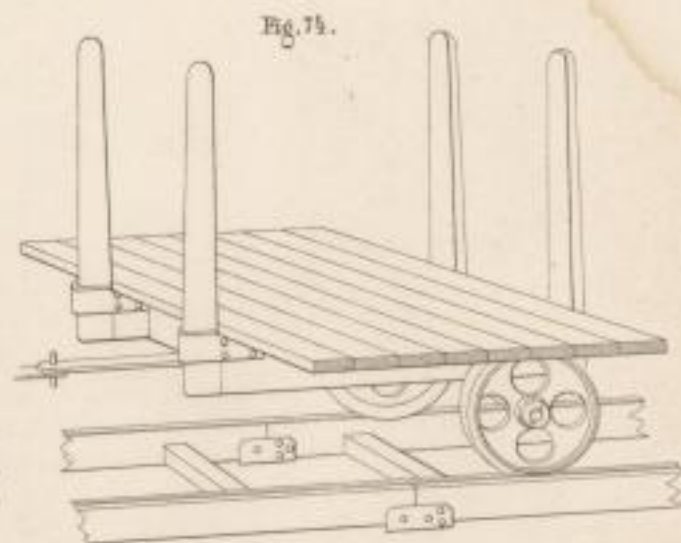

Fig. 74.

Landstraßen-Kaljer Holzbahn in Krain.

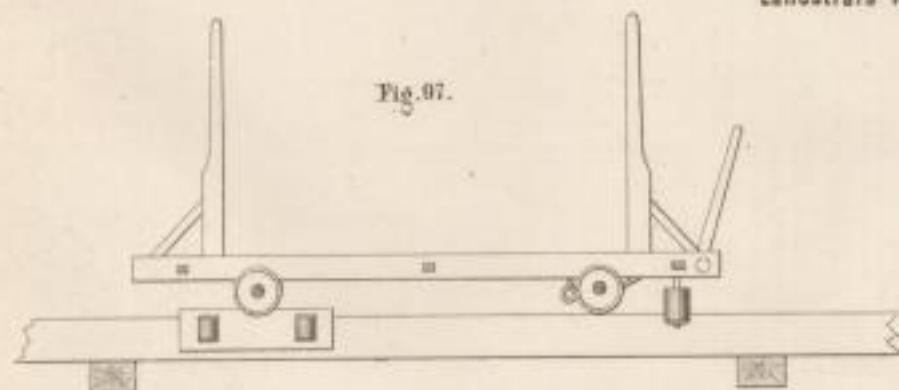

Fig. 97.

Fig. 97. Detail

1/60

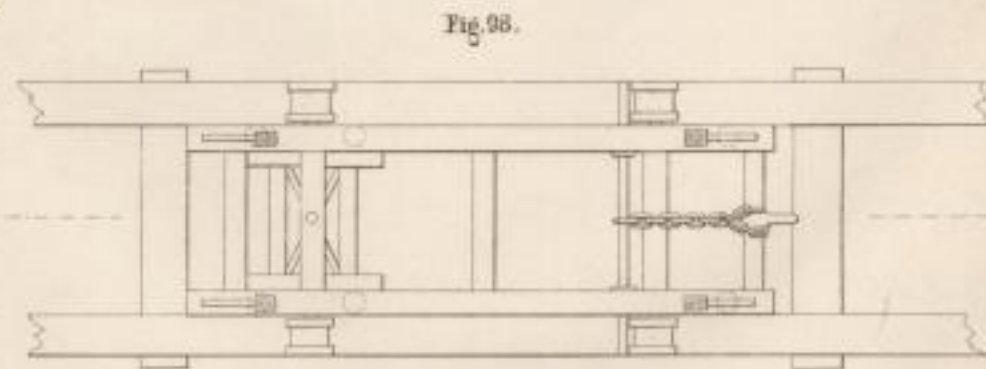

Fig. 98.

Fig. 98. Detail

Handwritten text, possibly a title or header, located at the top left of the page.

Handwritten text, possibly a date or reference number, located below the top left text.

Handwritten text, possibly a number or small label, located in the upper middle section.

Handwritten text, possibly a name or signature, located on the right side of the page.

Handwritten text, possibly a number or small label, located in the lower middle section.

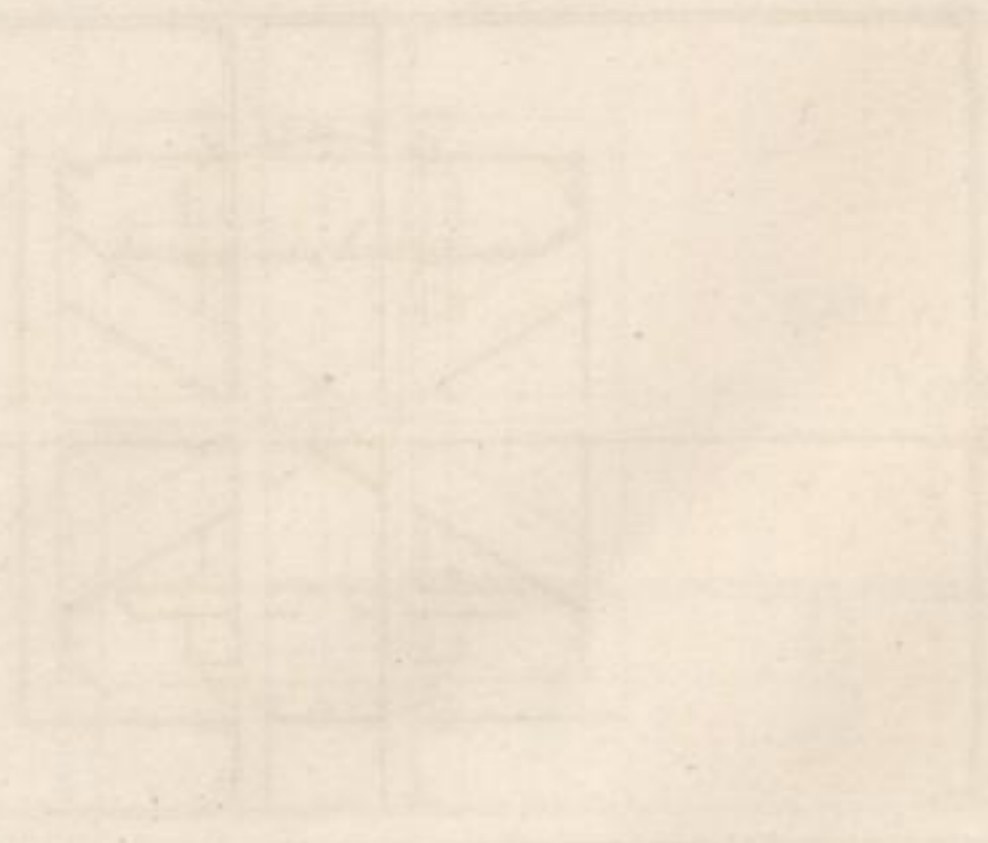

Achträdiger Lastwagen für Forst & Industriebahnen
(für Pferdebetrieb.)

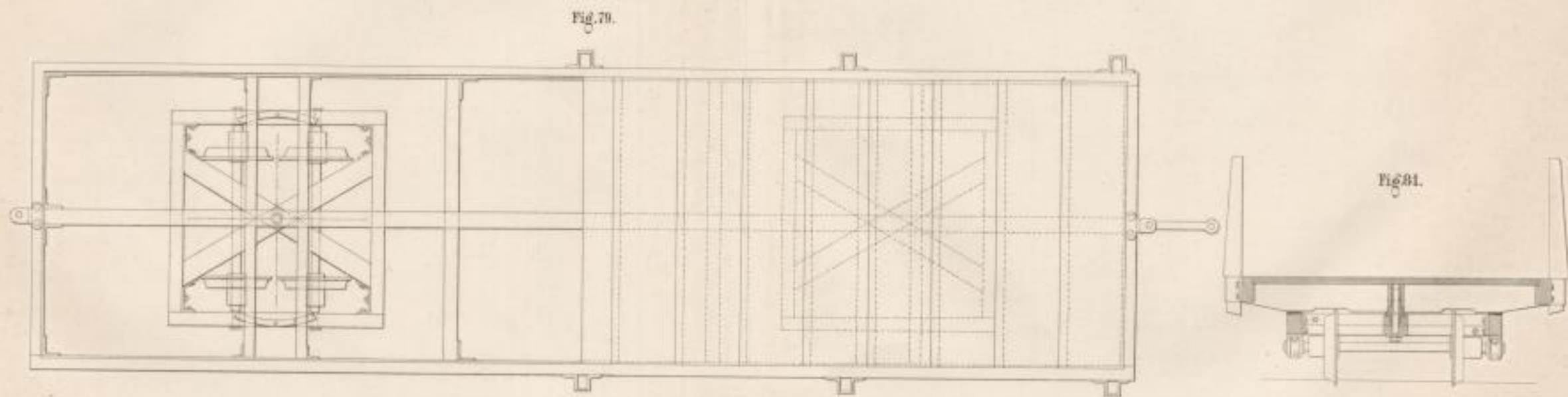
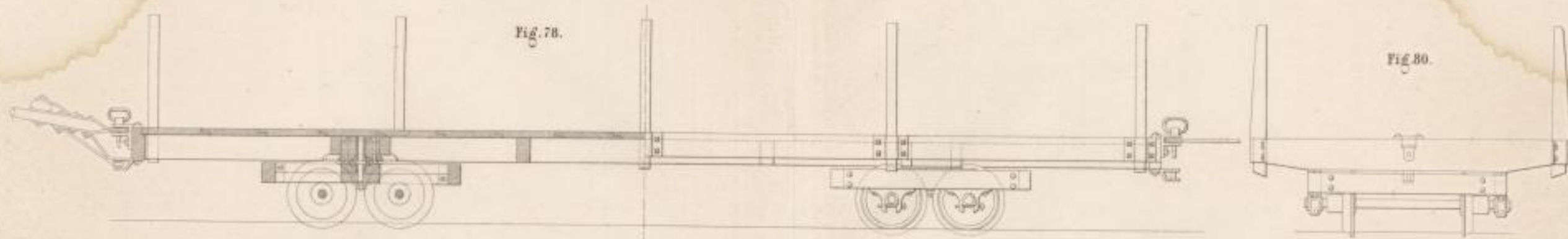

Original-Zeichnung

52.

IX 141

Abstrakte Darstellung von ...

...

...

...

Transportmittel auf der Kanalarbeit

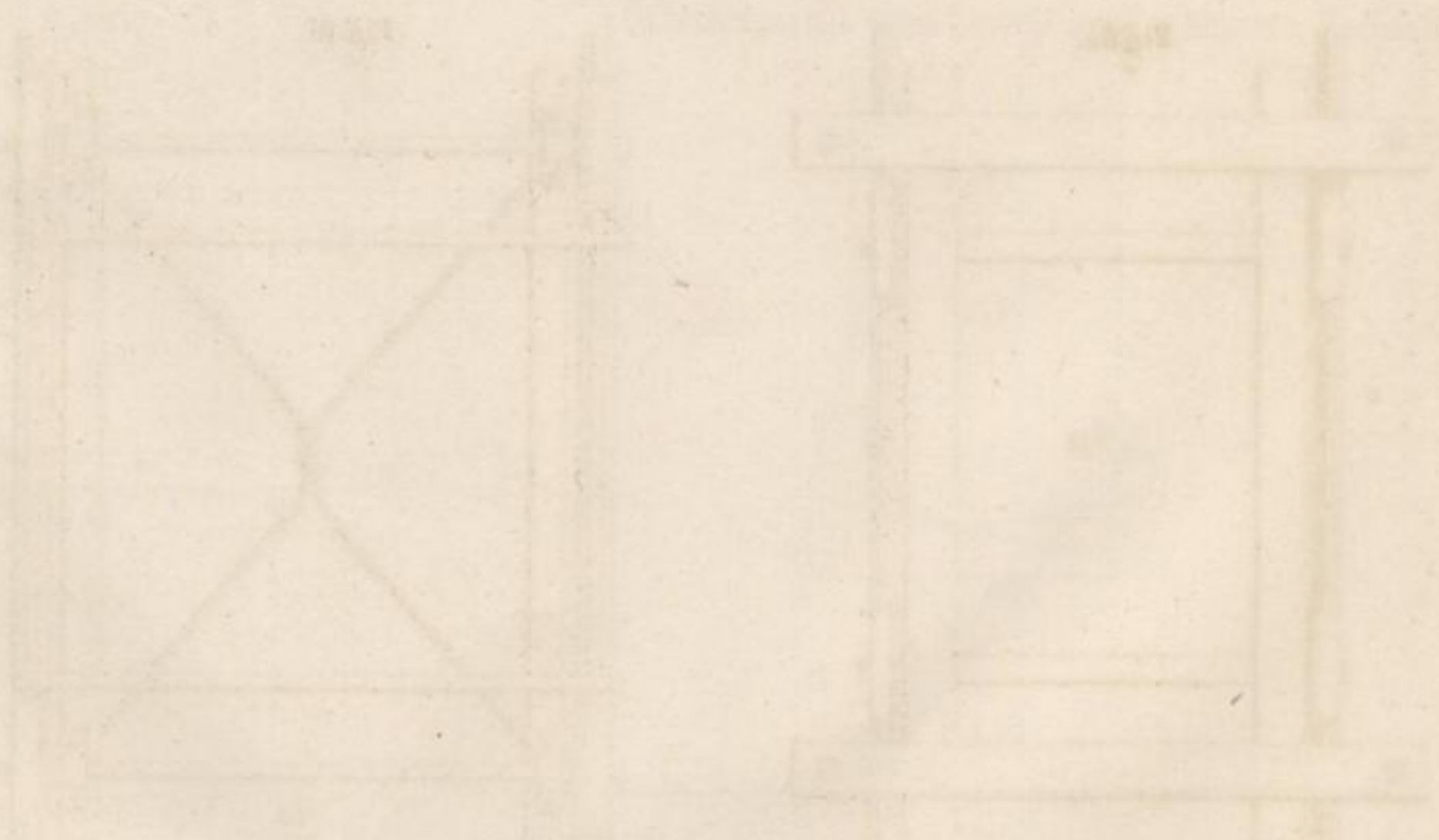

Transportmittel auf der Konkordia-Säge.

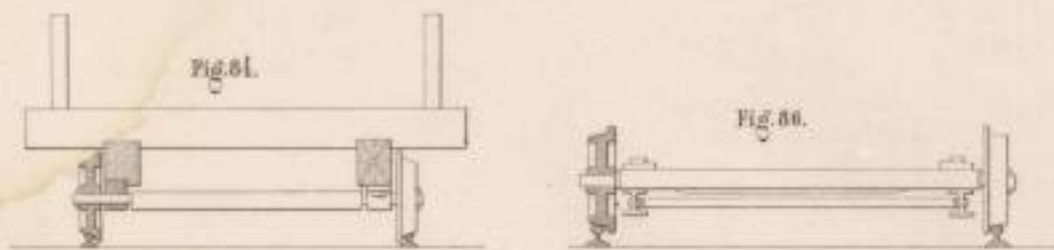

Lowry der Rothwald und Langau-Eisenbahn.

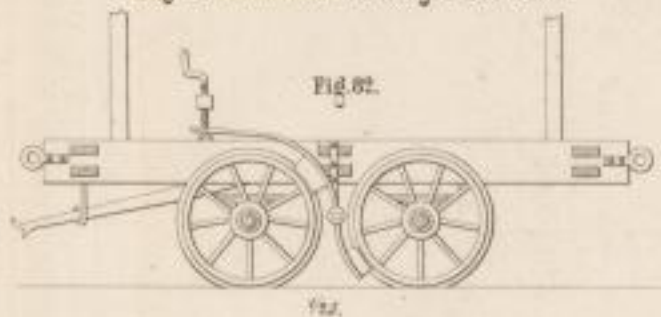

Detail des Zapfenlagers.

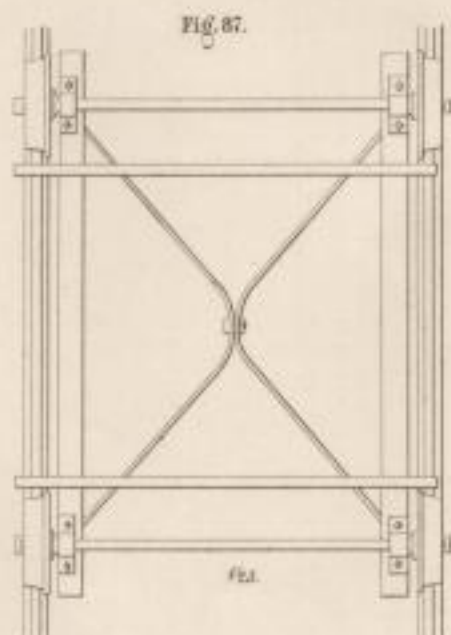
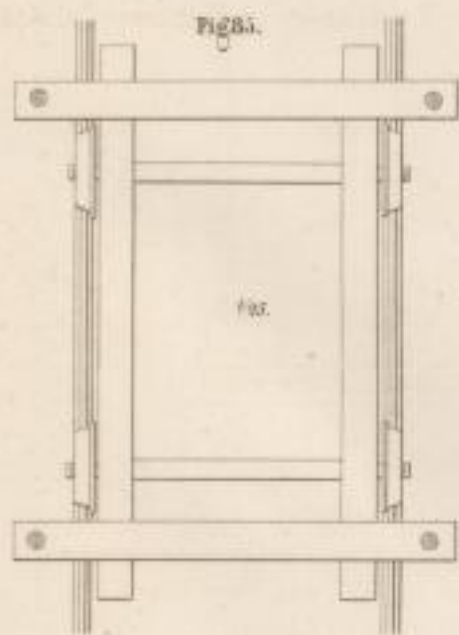
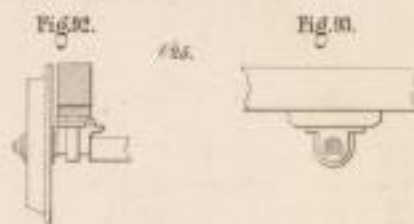
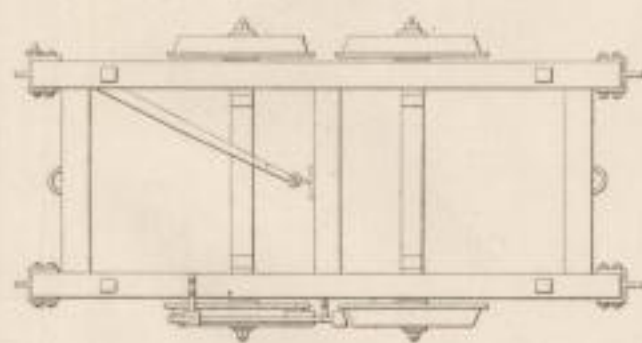

Fig. 83.



Schaukelgestell eines Lowry am Pöchlanner Rechenplatz.

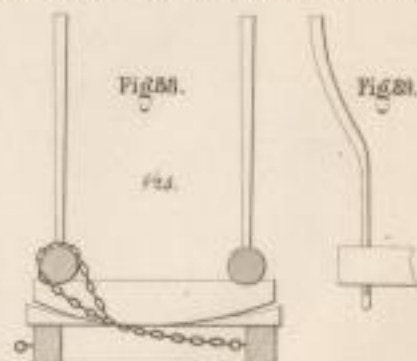

Fig. 90.

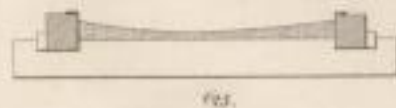
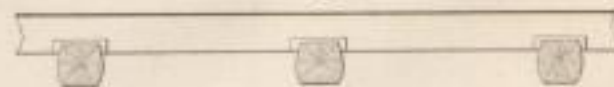

Fig. 91.



Einer Dampflokomotion.

Umsatz des Jahres



Umsatz des Jahres



Umsatz des Jahres





Einige Details von ...

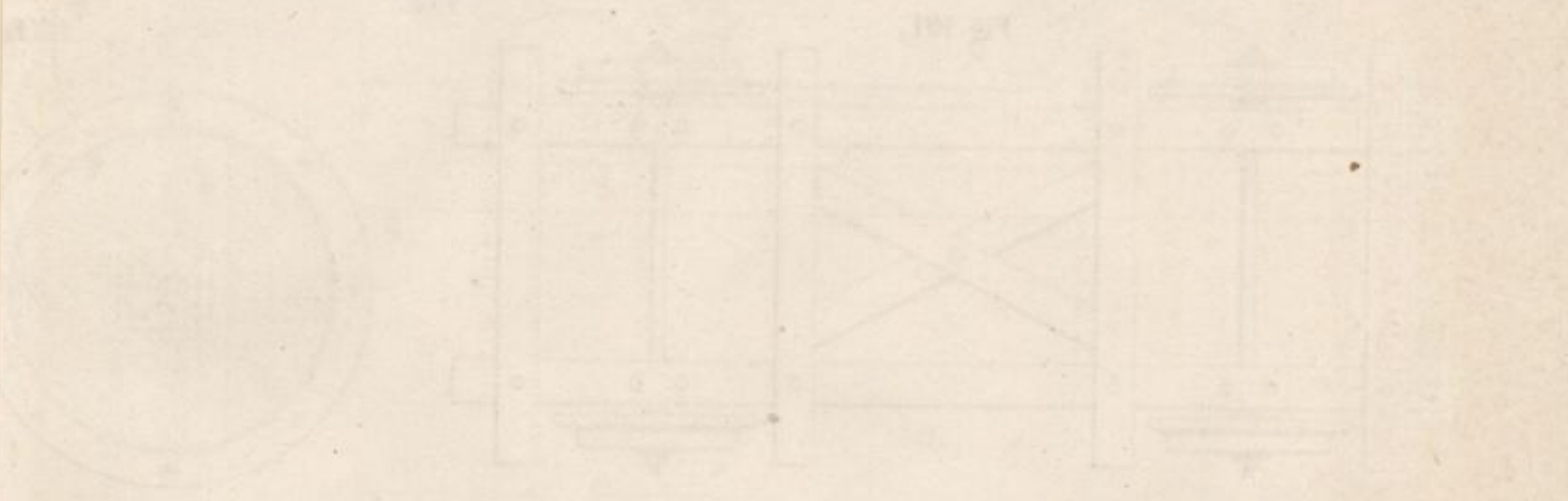

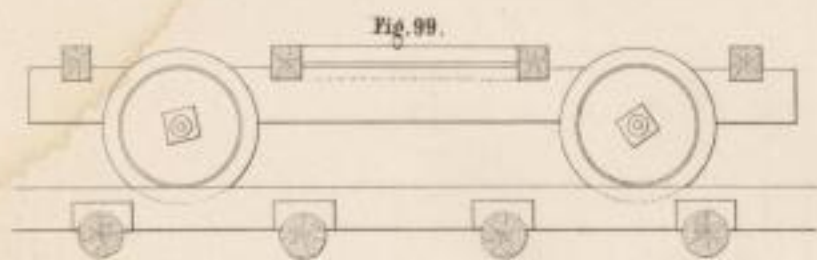

Fig. 99.

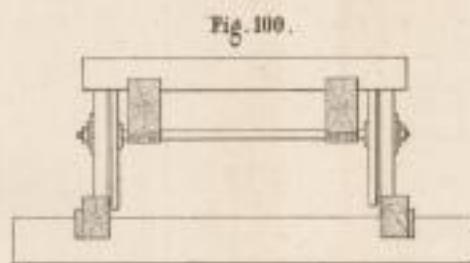

Fig. 100.

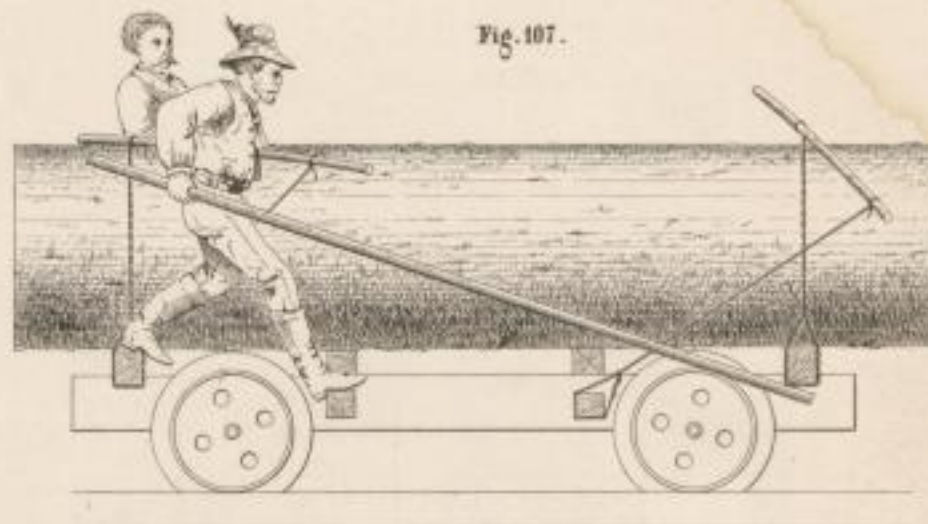

Fig. 107.

König's Rollbahn im Schlierenthal.

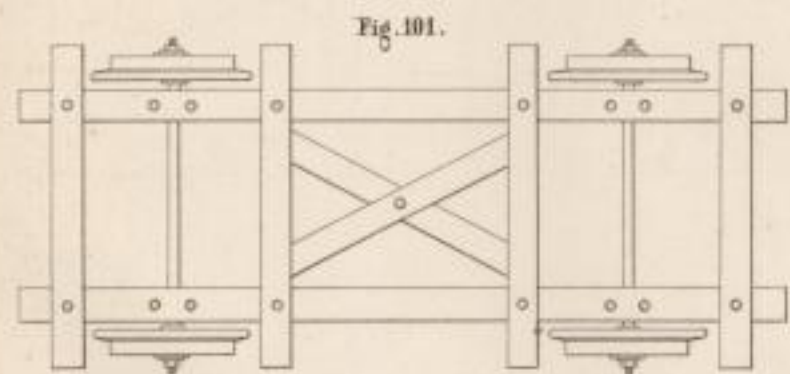

Fig. 101.

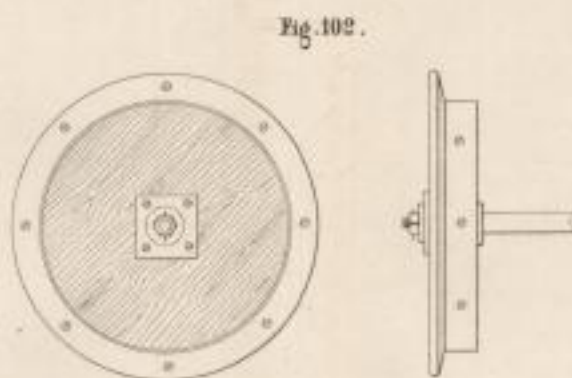

Fig. 102.

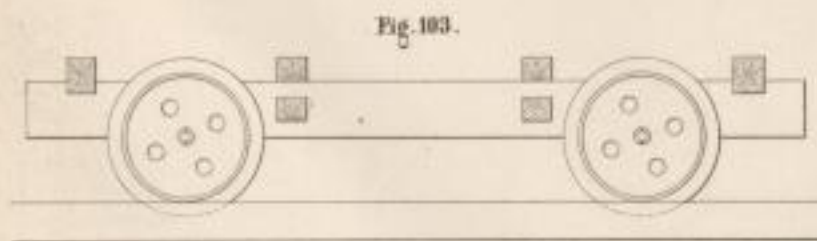

Fig. 103.

1/23

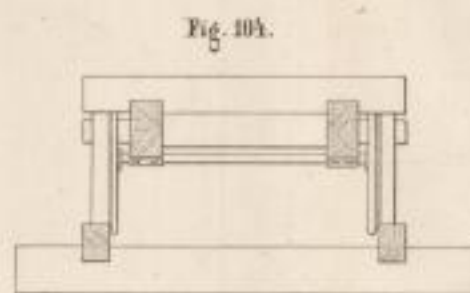

Fig. 104.



Fig. 105.

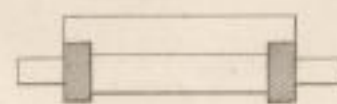
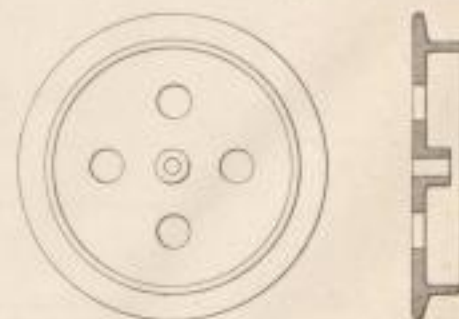
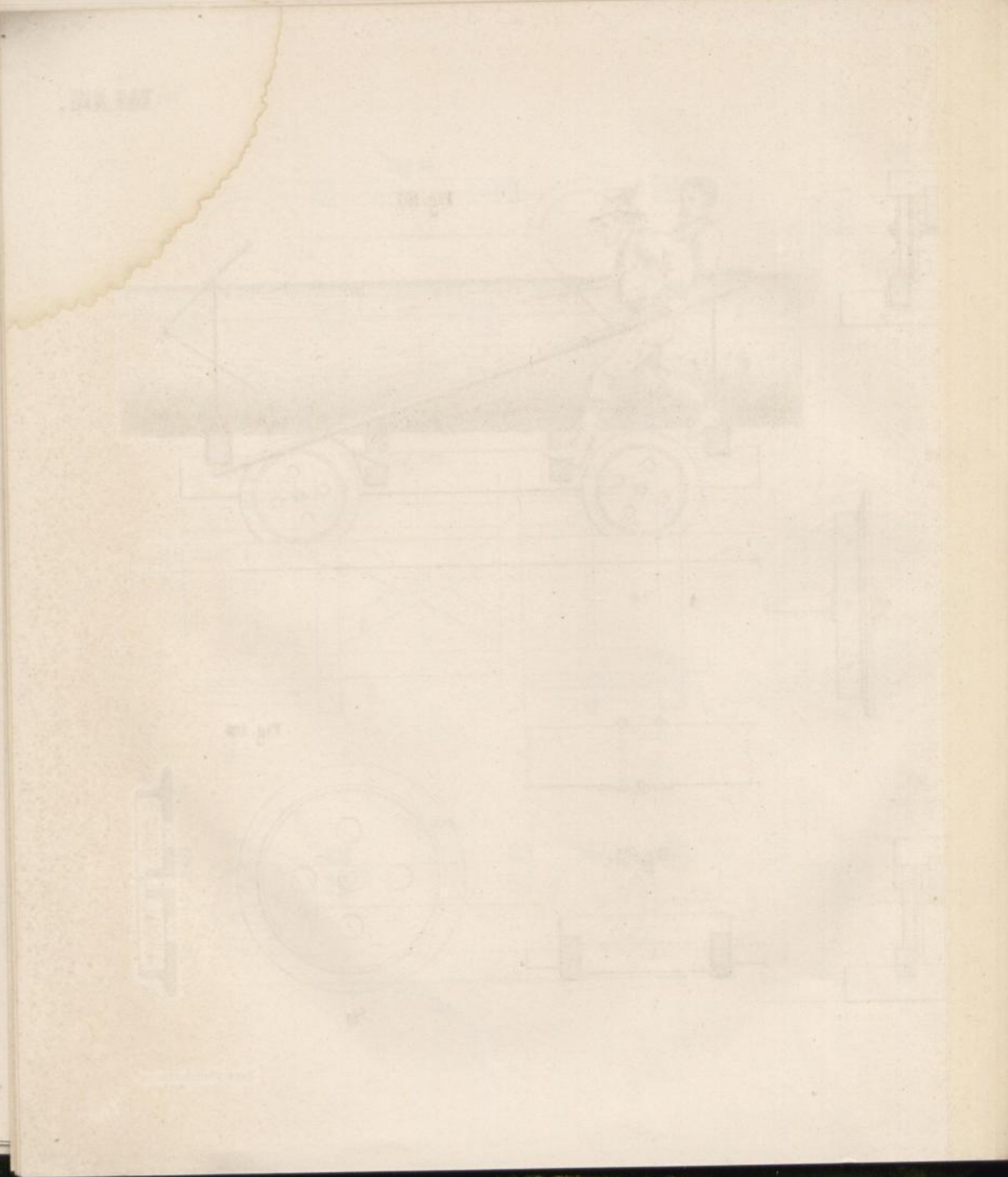

Fig. 106.



1/23

Lehr. Neupraxis



Platzwechsel des Himmels
L. 118



Fig. 118

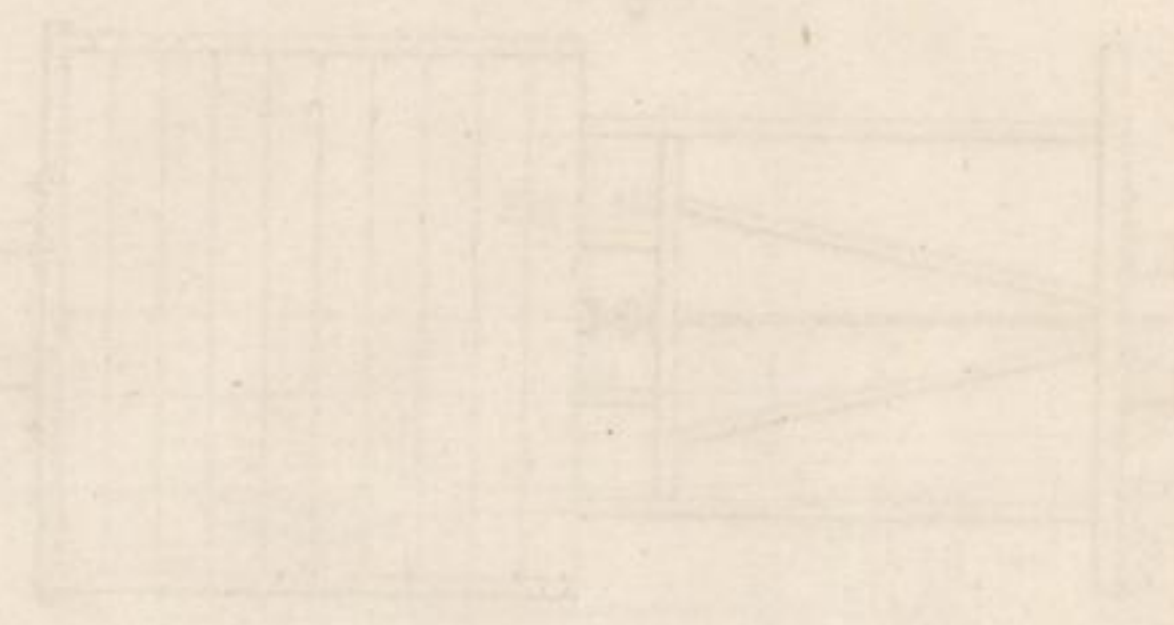

Fig. 111-118.

Plateauwagen ohne Bremse.

Fig. 113.

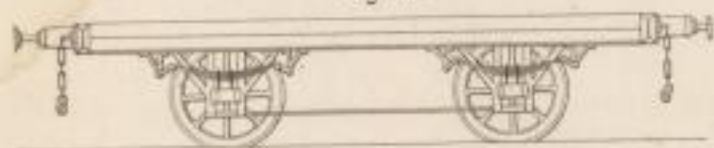
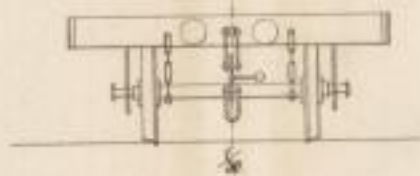

Fig. 115.



Offener Lastwagen mit Kippstook ohne Bremse.

Fig. 117.

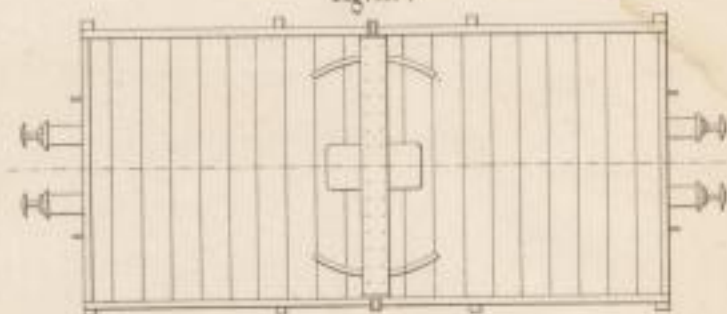

Fig. 114.

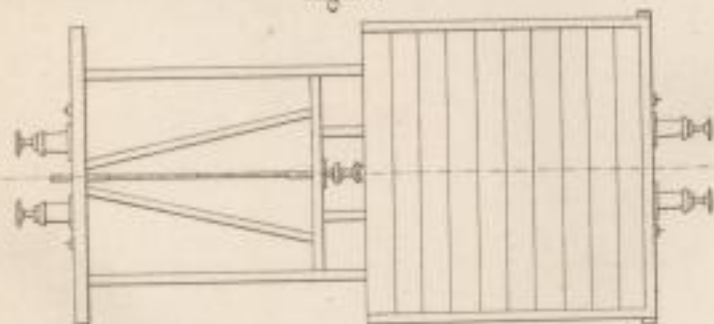

Fig. 118.

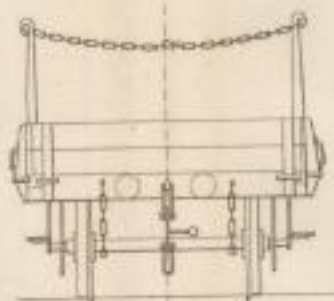

Fig. 116.

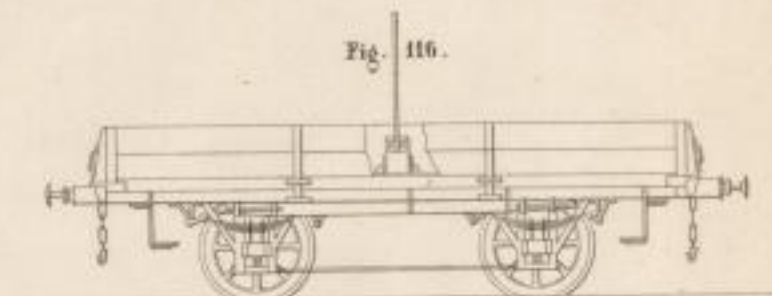
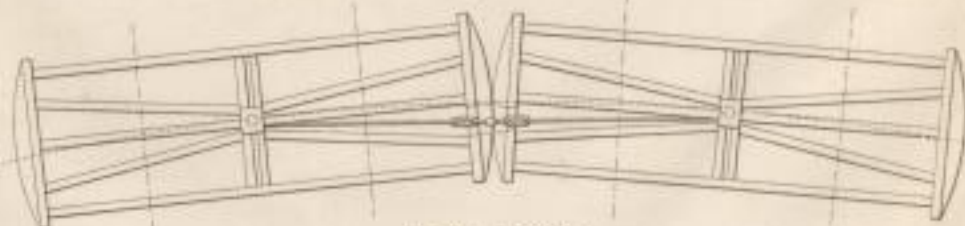
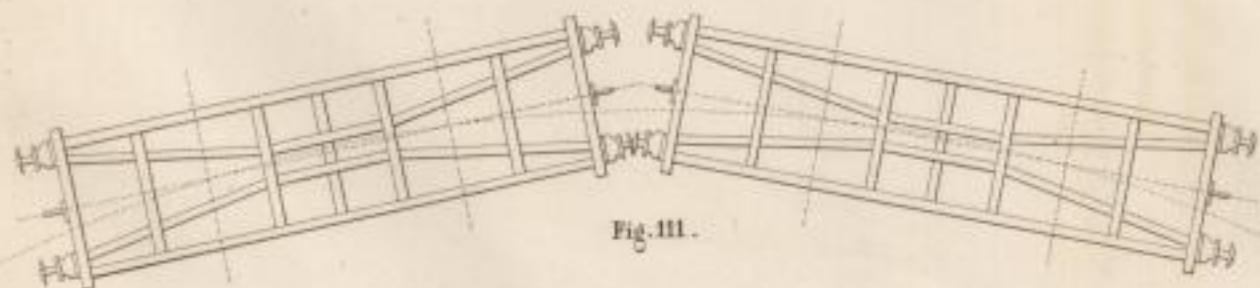

Fig. 112.



System Fairlie.

Fig. 111.



1811

Erster Teil des Buches

1811



1811



1811



1811

Fig. 118. 120. 124-131.

Drahtseilriese.

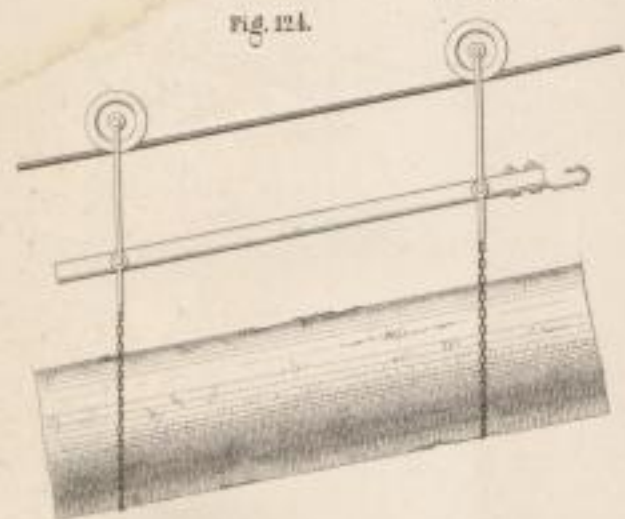

Fig. 124.

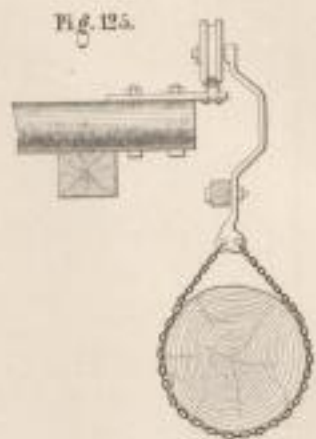

Fig. 125.



Fig. 127.



Fig. 128.

Bremsvorrichtung.

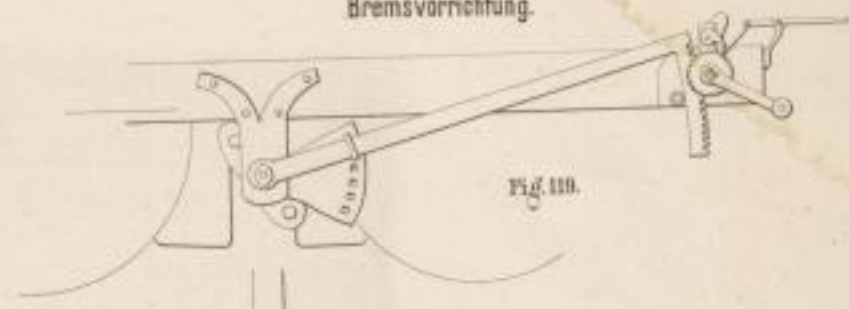

Fig. 119.

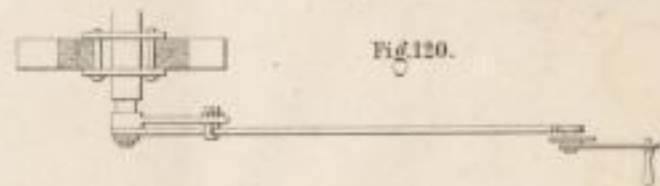
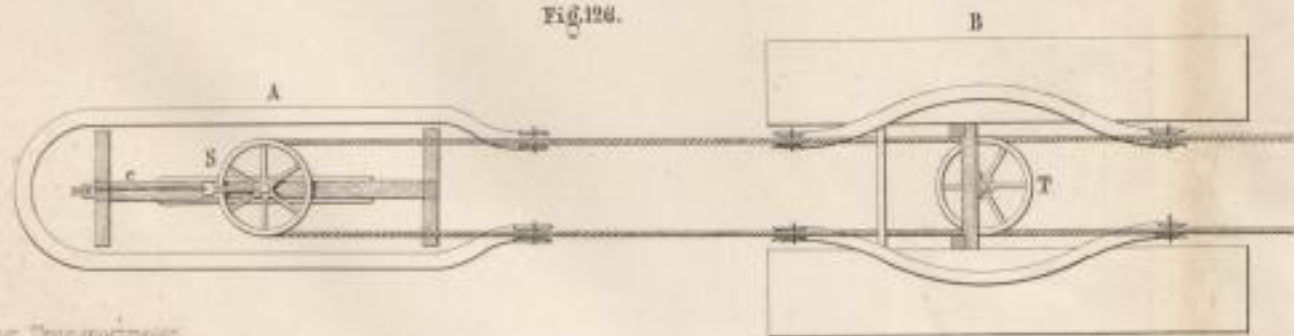

Fig. 120.

Hodgson's Seilbahnsystem.

Fig. 126.



Klein. Transportwagen.

Fig. 129.



Fig. 130.



Fig. 131.

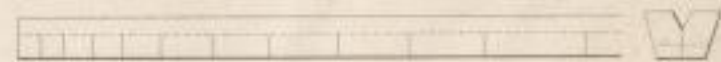

5A 3601

Verlag von Bernhard Friedrich Voigt in Weimar.

Dr. G. Marchet und Dr. W. F. Exner,

Holzhandel und Holzindustrie der Ostsee-Länder.

Ergebnisse einer Studien-Reise nach den deutschen und russischen Ostsee-Provinzen, Schweden, Dänemark und Hamburg; im Auftrag des k. k. österreichischen Ackerbau-Ministeriums veröffentlicht, für Holzhändler und Forstleute, Volkswirthe und Techniker. Mit statistischen Tabellen, in den Text eingedruckten Holzschnitten und einem Atlas von 16 Tafeln in gr. 4. Geh. 7 Mrk. 50 Pfge.

M. M. v. Weber,

die Praxis des Baues und Betriebes der

Secundärbahnen

mit normaler und schmaler Spur, welche Personen- und Güterverkehr führen. Kritische Erörterungen auf ausgeführten Bahnen gesammelter Thatsachen. Zweite vermehrte Auflage. gr. 8. Geh. 3 Mrk.

M. M. v. Weber,

neue Pfade der Volkswirtschaft.

Die Secundärbahnen mit normaler Spurweite und langsamer Fahrbewegung. Denkschrift. gr. 8. Geh. 90 Pfge.

H. v. Gerstenbergk,

der allzeit fertige Holz-Berechner

nach metrischem Mass-System, oder Tafeln, woraus nicht nur von runden, vierkantig behauenen und geschnittenen Hölzern der Inhalt nach Kubikmetern, sondern auch von letzteren der Inhalt nach Quadrat-Metern, auf's Genaueste und Zuverlässigste berechnet, sofort ersehen werden kann. Nebst Preis-Umwandlungs-Skalen und Geldberechnungs-Tabellen sowohl für die sämtlichen nord- und süd-deutschen, als auch für die österreichischen Staaten. Zum Gebrauche für Staats-, Forst- und Landwirthe, Waldbesitzer, Bauofficianten, Bau und Werkleute, Rheder, Schiffskapitaine, Holzhändler, Schneidemüller u. A. Zweite neu durchgesehene und vermehrte Auflage. gr. 12. Geh. 3 Mrk. 75 Pfge.

R. W. Höger,

der Arbeiter und das Gespann

als Arbeitskräfte der Landwirthschaft. Nach Darstellung der Mittel und Wege, die Arbeitskosten einer Wirthschaft zu vermindern, dem Mangel an ländlichen Arbeitern abzuheffen u. s. w. gr. 8. Geh. 1 Mrk.

Fr. Neumann,

der Führer des Technikers

zu den wichtigsten Resultaten der Mathematik, Mechanik, Maschinentechnik und Technologie. Für den praktischen Gebrauch des Maschinenbauers, Ingenieurs, Fabrikanten und Gewerbetreibenden bearbeitet. Fünfte verbesserte Auflage. Mit 10 Tafeln und 99 eingedruckten Holzschnitten. gr. 12. Geh. 7 Mrk. 50 Pfge.